

IONIC

GENBOX-1200S

User Manual

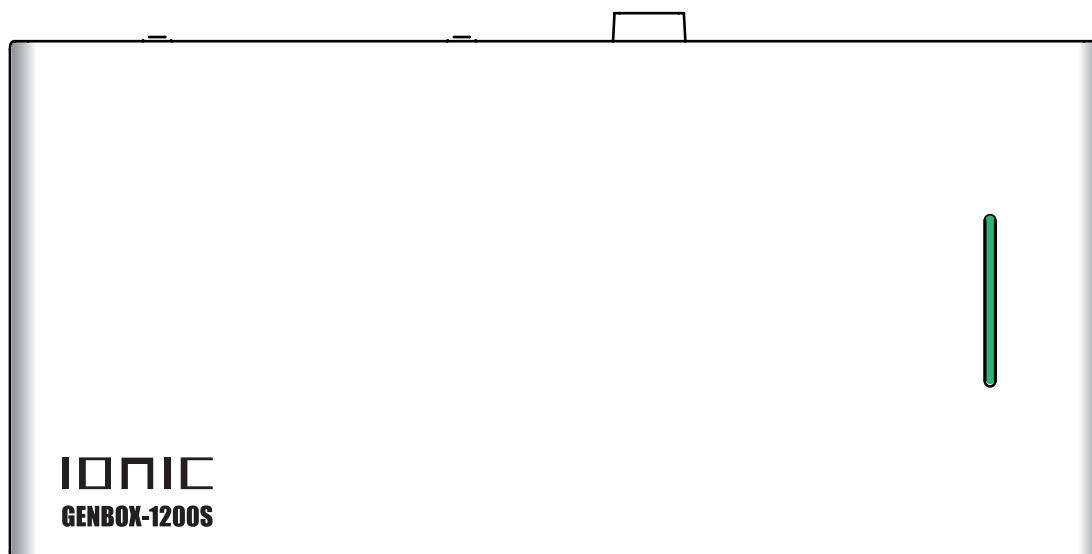

TABLE OF CONTENTS

1 GENERAL SAFTY RULES.....	02
2 PACKING LIST.....	03
3 GENBOX INTRODUCTION.....	03
4 GENBOX PRODUCT PANEL.....	04
5 GENBOX PARALLEL USE.....	05
6 GENBOX UPS & BYPASS MODE.....	05
7 GENBOX DC CHARGING.....	06
8 GENBOX SPECIFICATION.....	07
9 GENBOX TROUBLE SHOOTING.....	08
10 GENBOX CLEANING.....	09
11 TRANSPORTATION & STORAGE.....	09
12 GENBOX MAINTENANCE.....	09

01 GENERAL SAFTY RULES

WARNING!

1. Read this manual before using this product. Failure to follow the instructions and safety precautions in this manual can result in damage to the product or personal property, serious injury or death. **DO NOT** use the product with incompatible components or alter the product in any way.
2. Improper use may result in fire, property damage, or personal injury. Make sure to use the product according to the following safety rules and guidelines.
3. Do not expose the product to any liquid or submerge in water. If the battery comes into contact with water, it may cause chemical decomposition of the battery. This may cause the battery to catch fire or explode.

- DO NOT disassemble, repair or modify the unit or the battery module.
- DO NOT place the unit close to or in a fire or expose it to heat. Keep out of direct sunlight.
- DO NOT charge, use or store the unit in a bathroom or in an area exposed to rain or moisture.
- DO NOT touch the unit or the plug- in points if your hands are wet.
- DO NOT connect any metallic objects to the AC input or output.
- DO NOT dispose of the unit together with household waste.
- DO NOT use any inappropriate power cords.
- Only charge, use and store the unit within an ambient temperature of 0 to 40°C (32 ~104°F).
- Switch the unit OFF immediately if it has accidentally fallen, was dropped or was exposed to vibrations.
- Use of different cables will void the product's warranty and may cause damage or serious bodily injury.
- Use and store the unit only in a clean and dry environment. DO NOT use and store in a dusty and wet environment.
- Check the unit prior to every use. DO NOT use the unit if it is damaged or broken.
- DO NOT use the unit if the power cord is damaged or broken.
- Keep the unit away from children. DO NOT let children use the power supply unit.
- Keep this product away from pets.
- DO NOT use or store the unit in an area or environment with high temperature.
- DO NOT place the unit on its side or upside down while in use or storage.

All information in this document is subject to copyright and other intellectual property rights of Lithiumhub and its licensors. This material may not be modified, reproduced, or copied, in whole or in part, without the prior written permission of Lithiumhub and its licensors. Additional information is available upon request.

02 PACKING LIST

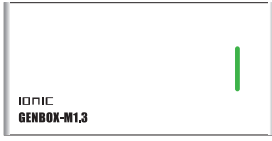

GENBOX-1200S

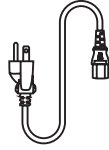

AC Charging Cable

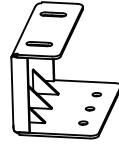

Stand/Mounting Bracket

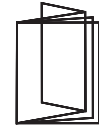

Manual

03 GENBOX INTRODUCTION

The ultimate solution for reliable backup power at home or on the go, the GENBOX is a LiFePO4 battery-based energy storage box that can be charged from an AC Grid, portable solar panels. The GENBOX offers 1.2 kW/1.3 kWh of battery capacity to power essential appliances during outages or when off-grid.

The following are the main features of this product:

- Equipped with 5,000 cycle LFP cell, the battery energy is 1382Wh.
- 1200W pure sine wave AC output can meet almost all daily electronic product and small household appliance needs.
- With fast charging technology, GENBOX can be recharged within 1.5h.
- In the UPS(Uninterrupted Power Supply) mode, allow for seamless switchover time of less than 20ms.

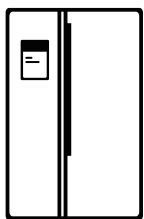

Refrigerator

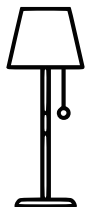

Floor Lamp

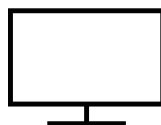

TV



Water Boiler

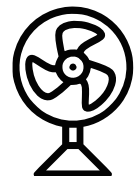

Fan

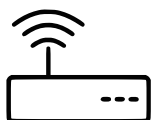

Wi-Fi



Phone



Drone



Switch 2



GoPro

04 GENBOX PRODUCT PANEL

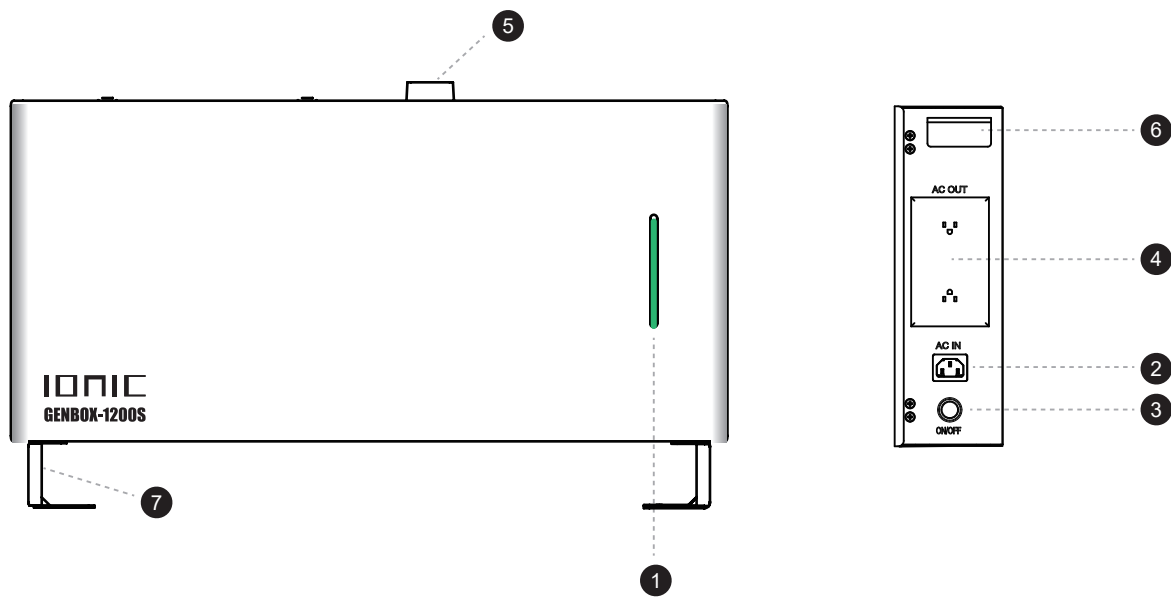

- ① Energy Level
- ② AC Input
- ③ On/Off Button
- ④ AC Output Ports
- ⑤ Battery Module Parallel Port
- ⑥ Lift Handle
- ⑦ Floor Mounted Bracket

Power On/Off

Short Press on/off button once to turn on the GENBOX. Press one more time to turn off. When all loads exceed the rated power, a reboot will be needed.

Energy Level

The LED Bar will show the real time energy level of GENBOX, when the energy level is less than 10% it will turn red.

Battery Module Parallel Port.

The battery module parallel port supports a max 4 pcs stack up for more energy usage, which makes the system 5.5kWh in total.

The DC Port also can connect to an external DC solar charging kit, which allows MAX.400W foldable solar panel to recharge GENBOX.

05 GENBOX PARALLEL USE

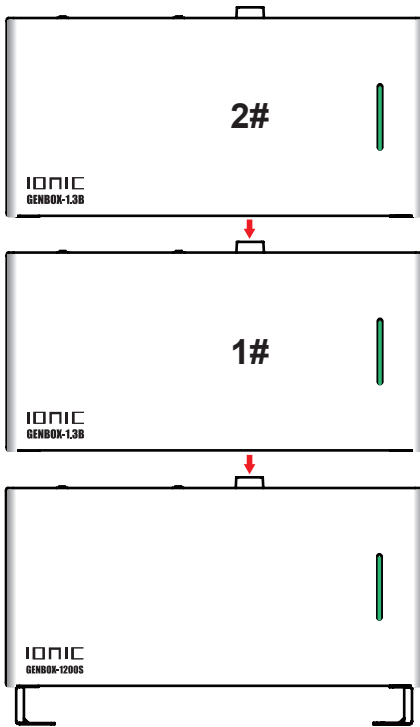

The GENBOX-1200S all in one unit, can be stacked with the battery module GENBOX-1.3B for the parallel use.

Step1. Turn off the GENBOX-1200S unit.

Step2. Stack the GENBOX-1.3B unit. Max.4 units

Step3. Install the side bracket to mount all units.

Step4. Turn on the GENBOX-1200S unit, and wait for all units to link up, the SOC bar will flash and show the whole system energy level.

06 GENBOX UPS & BYPASS MODE

UPS Feature

The GENBOX has the function of backup uninterruptible power supply, when the grid has a blackout. It will deliver the power to the loads within 20ms, through its inside bidirectional inverter. The loads power needs to be lower than 1,200W (110-120V), otherwise protection will be triggered.

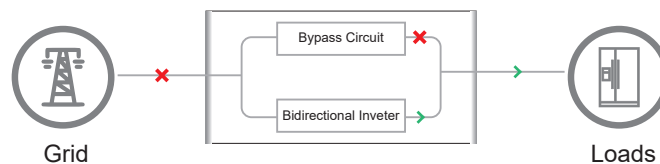

Bypass Feature

When the AC grid input port is connected, with one or more output ports also connected, the loads uses the power from the AC input source directly, and the remaining power drawn from the AC grid will charge up the GENBOX. The loads power needs to be lower than than 1,200W.

When the loads power keeps increasing, the battery charging current will drop down to min.4A.

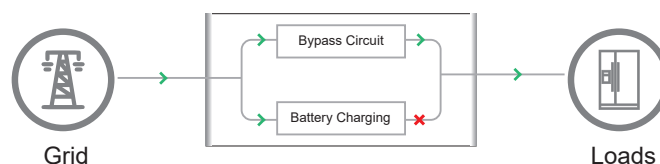

07 GENBOX DC CHARGING

The GENBOX-1200S has an external DC charging kit(optional), to allow you recharging by DC 12V car charging port or 400W max foldable solar panel.

Solar Charging Feature

The GENBOX accept one 20Vdc 200W solar panel input, or two 20Vdc 200W solar panel in **Parallel** connection, by using a “Y” type MC4 cable to link up.

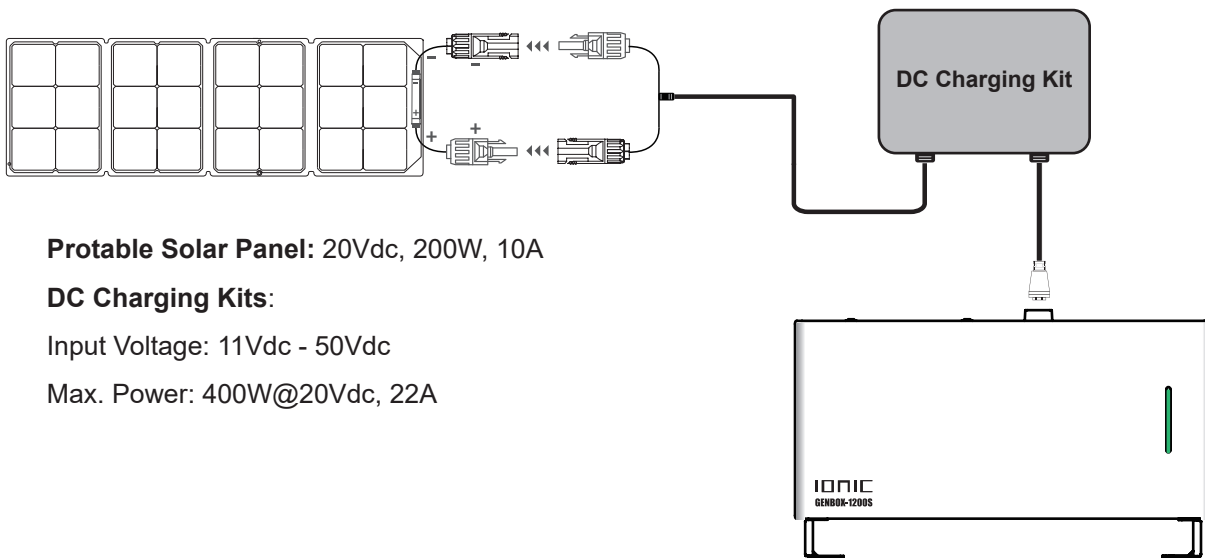

Portable Solar Panel: 20Vdc, 200W, 10A

DC Charging Kits:

Input Voltage: 11Vdc - 50Vdc

Max. Power: 400W@20Vdc, 22A

12V Car Charging Feature

The GENBOX accept Max.12Vdc 10A car charging input, it would take around 14~15h to fully recharge one unit.

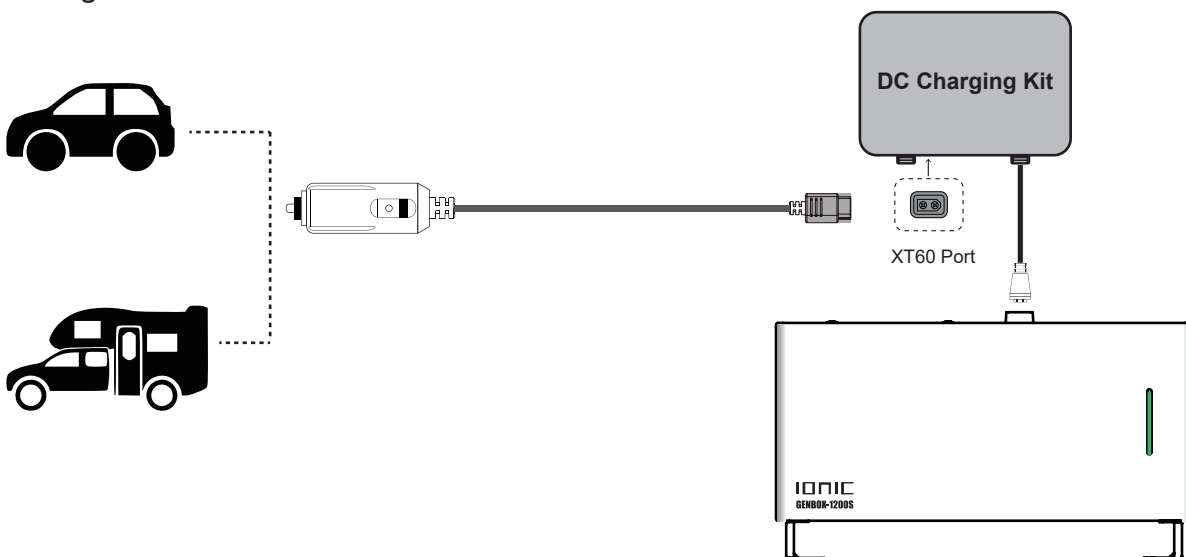

CAUTION: Do not charge the GENBOX with solar PV and car charging at the same time!

08 GENBOX SPECIFICATION

MODE	
GENBOX-1200S	GENBOX-1200S built-in LFP battery to power AC appliances at home. Integrated with pure sine inverter, and battery management system
Physical Characteristics	
Dimension(L*D*H)	25.4x3.8x12.0 inch (645*96*306mm)
Weight(kg/lbs)	33.0 lbs (15.0 kg)
Color	Black / White
Portable	Yes, built-with lift handles
AC OUTPUT	
2x AC 120V Port	1,200 VA (max continuous output power) 1,350 VA (peak output power) 120V 60Hz (L-N single-phase, pure sine wave)
AC Bypass Mode	1,200 VA
UPS Mode	<20 ms
AC round-trip efficiency	90%
INPUTS	
AC Grids Input	1,200 VA (L-N), 60Hz
DC Solar Input	Max. 400W, 15-20Vdc.
BUILD IN BATTERY	
Rated Capacity	1382 Wh.
Scalability	Max. 4pcs.
Battery Cycle	5,000 cycles to 70% SOC.
Battery Chemistry	LiFePO4.
COMPLIANCE	
Certificates	UL1642, UL1973-Cell UN38.3, FCC-Pack
Outdoor Use	IP54.

WARRANTY	
Limited Warranty	3 years factory warranty
ENVIRONMENT	
Charging Temperature	32°F to 122°F (0°C to 50°C)
Discharge Temperature	-4°F to 122°F (-20°C to 50°C)
Storage Temperature	41°F to 95°F (5°C to 35°C)
Operation Humidity	5% ~ 90%
Operation Altitude	6,560ft (2,000 m)

09 GENBOX TROUBLE SHOOTING

THE GENBOX DOES NOT DISCHARGE:

- (1) Check whether the on/off buttons are activated.
- (2) Check whether the total output power exceeds the rated output power.
- (3) Check whether the temperature of the equipment is too high.

THE GENBOX CANNOT BE CHARGED:

- (1) Confirm that the wall plug power cord is inserted fully into the AC Input.
- (2) If the device cannot be charged immediately after it is discharged, please wait for an hour and try again. It may be in the over-temperature protection mode.

IN THE EVENT THAT THE UNIT CATCHES FIRE:

Never attempt to extinguish a fire if it is unsafe to do so. Contact your local fire department. If it is safe to do so use an Lithium appropriate fire extinguisher. Do not touch any hot or burnt components. Dispose of the unit only when safe to do so after the unit is extinguished and fully cooled.

GETTING THE BATTERY PACK WET.

Warning: Getting your battery pack wet could cause electric shock or other bodily harm. Never attempt to power on a wet battery pack.

- (1) Surface Water: If your battery pack was lightly splashed with water, wipe the unit dry and allow it to fully dry for several hours before powering on.
- (2) Water got inside: If water has entered the battery pack, place it in a safe area until fully dry. Do not attempt to power the battery pack on and dispose of the battery pack in accordance with local laws.
- (3) Battery fell into water: Do not attempt to retrieve the battery back and contact your local fire department for guidance. If the unit is retrieved from the water, place it in a safe area until fully dry and dispose of it properly in accordance with proper battery disposal.

10 GENBOX CLEANING

Be sure that the GENBOX is disconnected from all input power sources and output devices. Use a clean, dry, lint-free cloth to wipe it down. Remove any debris, dirt, or other blockages on both side vents. When cleaning debris from the side vents, do not allow the debris, dirt or other blockages to enter the body of the product.



DO NOT use abrasive cleaners or solvents.

DO NOT use compressed air to clean side cooling vents, as this will force foreign particles into the internal circuitry.

To avoid the risk of electrical shock, DO NOT use metal objects to clean ports.

11 TRANSPORTATION & STORAGE

- Battery life may be reduced if not used for an extended period of time. Discharge the GENBOX to 30% battery life, then charge to 85% every 3 months to prolong battery life.
- Store indoors, in cool temperatures, mild humidity, and away from direct sunlight.
- Charge the GENBOX to 100% before long time storage.
- DO NOT place the product near a heat source, such as a car in direct sunlight, a fire source, or a heating stove.
- Leaving in a vehicle or other confined spaces in extreme hot temperatures can lead to decreased service life, overheating, and fire. Extreme cold conditions below specific storage range can also harm the product performance and service life.
- Store the product in a dry environment. DO NOT place the product where it may contact water or high humidity. Keep away from corrosive chemicals and gasses.
- Make sure no small metal objects can fall on or around the product while in storage.
- Never transport a product with a battery power level higher than 30%.
- Never store the product in environments below -4° (-20°C) or above 113° (45°C).

12 GENBOX MAINTENANCE

Recharge as needed. There are no pre-designated intervals at which to recharge as long as the product is being used regularly. Avoid discharging completely on a regular basis, as this can impact overall lifespan. Regularly inspect all ports and wall charger for any debris, dirt, damage and corrosion.

DO NOT attempt to repair.

DO NOT cover the product with towels, clothing or other items. Regularly check if the side vents are collecting dirt or dust, and clean following cleaning procedures noted in manual.